

Series Number:

5400

Type:
**Bench Top or
Floor Stand**

Vessel Sizes, mL:
5 mL - 1000 mL

Standard Pressure
MAWP Rating, psi (bar):
**1500 (100)
3000 (207)
4500 (300)**

Maximum Operating
Temperature, °C:
350 or 550

Series 5400 Continuous Flow Tubular Reactor Systems

Tubular reactors are used in a continuous flow mode with reagents flowing in and products being removed. They can be the simplest of all reactor designs. Tubular reactors are often referred to by a variety of names:

- Pipe reactors
- Packed-bed reactors
- Fixed-bed reactors
- Trickle-bed reactors
- Bubble-column reactors
- Ebullating-bed reactors

Single-phase flow in a tubular reactor can be upward or downward. Two-phase flow can be co-current up-flow, counter-current (liquid down, gas up) or, most commonly, co-current down-flow.

Tubular reactors can have a single wall and be heated with an external electric furnace or they can be jacketed for heating or cooling with a circulating heat transfer fluid. External furnaces are typically rigid, split-tube heaters. Tubular reactors are used in a variety of industries:

- Petroleum
- Petrochemical
- Polymer
- Pharmaceutical
- Waste Treatment
- Specialty Chemical
- Alternative Energy

Tubular reactors are used in a variety of applications, including:

- Carbonylation
- Hydrogenation
- Hydrogenation
- Hydrocracking
- Hydroformulation
- Oxidative decomposition
- Partial oxidation
- Polymerization
- Reforming

Tubular reactors may be empty for homogenous reactions or packed with catalyst or other solid particles for heterogeneous reactions. Packed reactors require upper and lower supports to hold particles in place. Upper packing often includes inert material to serve as a pre-heat section. Pre-heating can also be done with an internal spiral channel to keep incoming reagents close to the heated wall during entry, as shown above.

It is often desirable to size a tubular reactor to be large enough to fit 8 to 10 catalyst particles across the diameter and be at least 40-50 particle diameters long. The length to diameter ratio can be varied to study the effect of catalyst bed length by equipping the reactor with "spools" placed into the bottom of the reactor to change this ratio.



Model 5403 with a 1" inside dia. x 24" length, 3-zone split tube furnace with gas feed system, cooling condenser, and gas/liquid separator vessel.

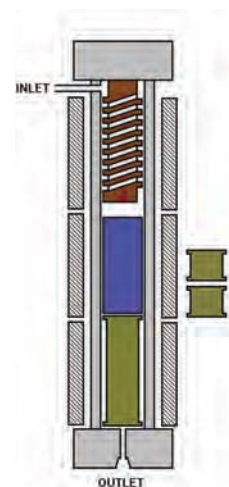



Open 3-zone Split Tube Furnace with 1" I.D. Tubular Reactor.

Tubular reactor systems are highly customizable and can be made to various lengths and diameters and engineered for various pressures and temperatures, and materials of construction.

A split-tube furnace is provided for heating these vessels. Insulation is provided at each end to minimize heat losses and prevent the end caps from being heated. The heater length is normally divided into one, two, or three separate heating zones, although it can be split into more zones if required.

A fixed internal thermocouple in each zone can be furnished or a single movable thermocouple in a centerline thermowell can be used to measure the temperature at points along the catalyst bed. External thermocouples are typically provided for control of each zone of the heater, as can be seen in the photo above.

Gas Feed Systems

Various gas feeds can be set up and operated from a **Gas Distribution Rack**. In order to deliver a steady flow of gas to a reactor, it is necessary to provide gas at a constant pressure to an electronic **Mass Flow Controller**. This instrument will compare the actual flow rate delivered to the set point chosen by the user, and automatically adjust an integral control valve to assure a constant flow.

Series 5400 Tubular Reactor System Specifications

Shaded bar indicates specifications that change within series.

Model Number	5401	5402	5403	5404
Sizes	3/8 in.	1/2 in.	1.0 in.	1.5 in.
O.D. / I.D. (in.)	0.38 / 0.28	0.50 / 0.37	1.50 / 0.99	1.88 / 1.44
O.D. / I.D. (mm)	9.5 / 7.0	13 / 9.5	38 / 25	48 / 36
Heated Length (in.)	6, 12, 24		12, 24, 36	
Maximum Pressure (psi)	3000		5000	3000
Maximum Temperature	550		550	350
Support Spools	No		Optional	
Spiral Pre-Heat	No		Optional	
No. Ports in Top Head	1		4	
No. Ports in Bottom Head	1		4	
Internal Thermocouple	Optional (Moveable or multi-point fixed)			

Care must be taken to size these controllers for the specific gas, flow rate range, and maximum pressure of operation. A mass flow controller needs a power supply and read-out device, as well as a means of introducing the desired set point.

When ordering mass flow controllers, you will need to specify:

1. Type of gas to be metered (e.g. N₂, H₂, CH₄)
2. Maximum operating pressure of the gas (100 or 300 bar)
3. Maximum flow rate range in standard cc's per minute (sccm)
4. Pressure for calibration of the instrument

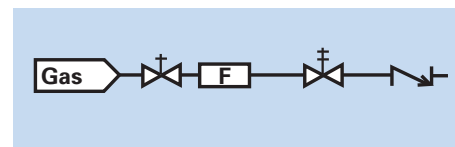
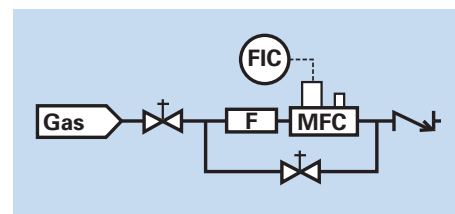

Mass flow controllers are available for use to 1500 psi and to 4500 psi. Considerable savings can be obtained if the mass flow controller is to be used only to 1500 psi.

The schematic at right depicts the installation of a mass flow controller for the introduction of gas to a continuous-flow reaction system. Such installations are enhanced with the addition of a by-pass valve for rapid filling or flushing.

A purge line can also be added. It is typically used for feeding nitrogen or helium to remove air before reaction or to remove reactive gases before opening the reactor at the end of a run. The purge line includes a shut-off valve, filter, metering valve, and a reverse-flow check valve.

Shut-off valves can be automated when using a 4871 Control system.

Series 5400 Continuous Flow Tubular Reactor Systems



This 1 liter Tubular Reactor System has two gas feeds, one purge line, and one liquid feed. Custom pressure controls enhance the heated gas/liquid separator.

Liquid Metering Pumps

High pressure piston pumps are most often used to inject liquids into a pressurized reactor operating in a continuous-flow mode. For low flow rates, HPLC pumps, many of which are rated for 5000 psig, are excellent choices. Typical flow rates for pumps of this type range up to 10 or 40 mL per minute. Pumps are available to accommodate manual control from their digital faceplate or computer-control from a 4871 Process Controller.

Chemical feed pumps are our recommendation for continuous feeding of liquids when the desired flow rate is greater than 2 liters per hour. Parr can assist with the feed pump selection. We will need to know the type of liquid; the minimum, typical, and maximum desired feed rate; the maximum operating pressure; and any special operating considerations such as corrosion possibilities.

Cooling Condensers

Cooling condensers are available to cool the products of the reaction. An adaptation of our standard condensers provides an excellent design.

Back Pressure Regulators

The reactor pressure is maintained by a Back Pressure Regulator (BPR) installed downstream of the reactor. This style of regulator will release products only when the reactor pressure exceeds a value preset by the operator.

When a BPR is used in conjunction with mass flow controllers, the user can maintain a constant flow of gas through a reactor held at an elevated constant pressure. This provides for the highest degree of control and reproducibility in a continuous-flow reactor system.

An alternate BPR may be available to permit pressure let-down of a two-phase stream from the reactor. This BPR requires that the operator provide a source of nitrogen or air at a pressure slightly above the desired operating pressure. With this style of BPR, the high-pressure gas/liquid separator can be replaced with a low-pressure liquid product receiver allowing collection of near real-time liquid samples.



This continuous flow stirred reactor system is on a cart with our Modular Frame System. This modular frame allows for easy access and flexibility in hook-ups, accessories, and flow, including an interchangeable tubular reactor.

Gas/Liquid Separators

Tubular reactors operating in continuous-flow mode with both gas and liquid products will typically require a Gas/Liquid Separator. The separator is placed downstream of the reactor, often separated from the reactor by a cooling condenser. In the separator vessel, liquids are condensed and collected in the bottom of the vessel. Gases and non-condensed vapors are allowed to leave the top of the vessel and pass to the back pressure regulator. It is important to operate the standard BPR with a single fluid phase to prevent oscillation of the reactor pressure.

The gas/liquid separator can be sized large enough to act as a liquid product receiver that is drained periodically. Many of the non-stirred pressure vessels made by Parr are ideally suited for use as gas/liquid separators. Vessels of 300, 600, 1000, or 2000 mL are commonly chosen. Upon request, the bottom of the separator can be tapered to facilitate draining.



This tubular reactor system features a single-zone 12-inch long heater to take reactor temperatures to 500 °C. The gas feed system includes automated shut-off valves on the three MFCs and on the purge line. The Gas/Liquid Separator vessel is jacketed to allow for subambient cooling. Operator controls the system via a remote PC using the included Model 4871 Process Controller.

Series 5400 Continuous Flow Tubular Reactor Systems

On this page are schematic representations of typical tubular reactor systems, along with a symbols chart to facilitate understanding. We have provided an ordering number for each of these examples.

Key to Symbols

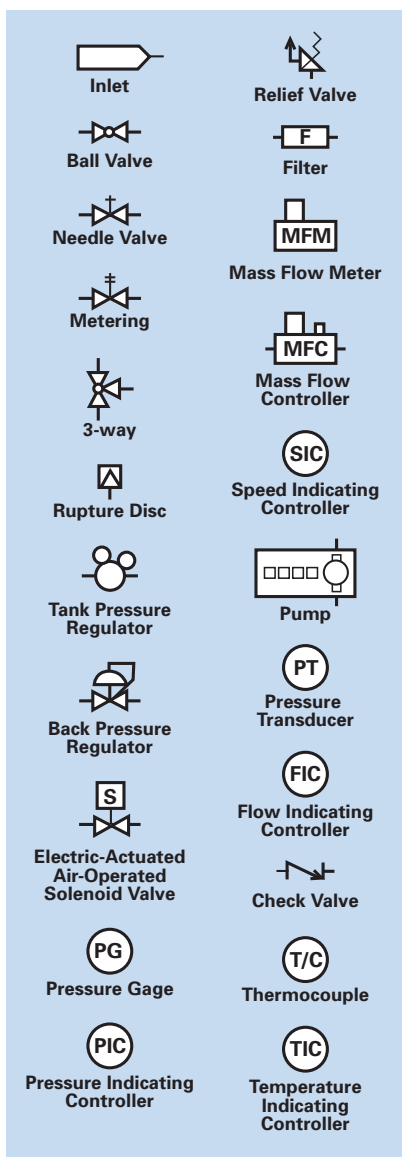

Order No. for this system would be:

5402B-SS-115-ST1(6)-1500-LCS-GF(1)-PL-LF(1)-ITW-CCD-GLS(300)-MPC

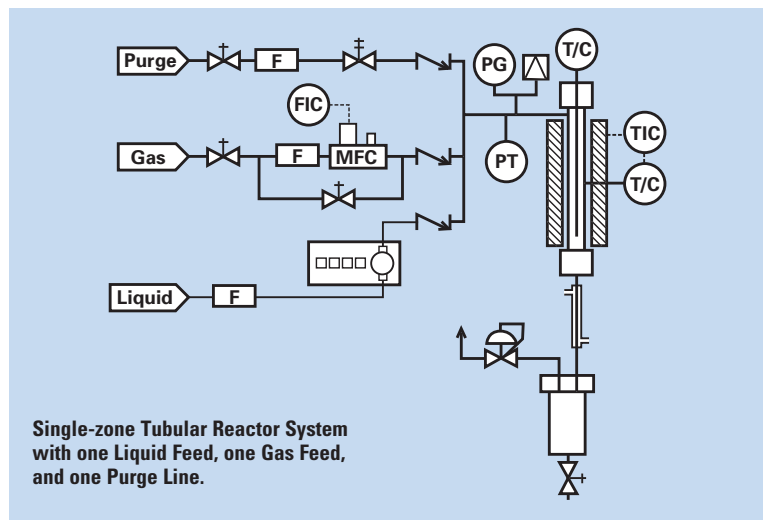

Order No. for this system would be:

5403F-SS-230-ST3(24)-3000-PCC-GF(2)-PL-LF(1)-ISP-CSS-ITW-GLS(600)-APC-ASV(3)

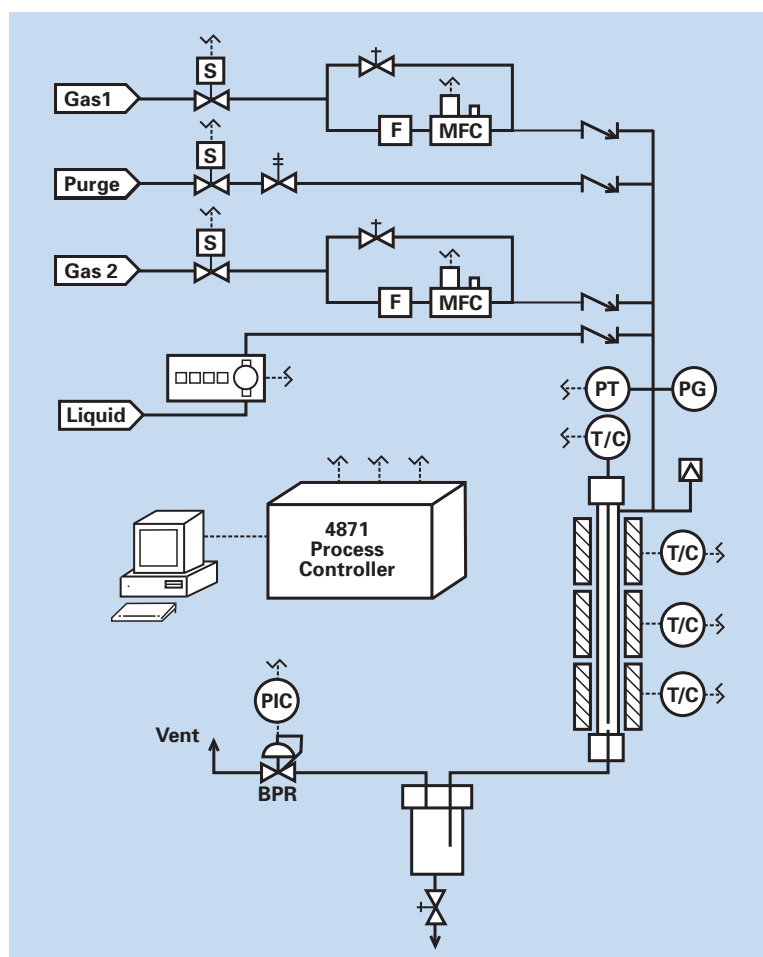

Series 5400 Ordering Guide

A composite identification number to be used when ordering a 5400 Series Reactor can be developed by combining individual symbols from the separate sections below.

A Base Model	
Model No.	Size (O.D. / I.D.)
5401	3/8 in. (0.38" / 0.28")
5402	1/2 in. (0.50" / 0.37")
5403	1.0 in. (1.9" / 1.0")
5404	1.5 in. (2.0" / 1.5")

Add suffix F for Floor Stand mounting
Add suffix B for Bench Top mounting

B Materials of Construction	
-SS	T316 Stainless Steel
-HC	Alloy 276
-TI	Titanium
-IN	Alloy 600
-MO	Alloy 400

C Electrical Supply	
-115	115 VAC, 50/60Hz
-230	230 VAC, 50/60Hz

D Heater Options	
-ST1(#)	Split Tube, 1-zone
-ST3(#)	Split Tube, 3-zone
-WJ(#)	Welded Jacket

Add suffix (6), (12), (24), (36) for heated length (in.)

E Maximum Operating Pressure	
-1500	1500 psi / 100 bar
-3000	3000 psi / 200 bar
-4500	4500 psi / 300 bar

F Controller	
-PCC	PC-based Process Control (4871-style)
-LCS	Local Control System (4838-style)

G Custom Options	
-GF(#)	Number of Gas Feeds
-PL	Purge Gas Feed Line
-LF(#)	Number of Liquid Feeds
-ISP	Internal Pre-heat Spiral (5403/5404 only)
-CSS	Catalyst Support Spools (5403/5404 only)
-ITW	Internal Thermowell, with Movable T/C
-IZT	Internal, 3-PT, Fixed T/C
-CCD	Cooling Condenser
-GLS(#)	Gas/Liquid Separator (300, 600, 1000, 2000 mL)
-SPH	Separator Heater
-MPC	Manual Pressure Control
-APC*	Automated Pressure Control
-ASV(#)*	Automated Shut-off Valves (1-12)

*Available only with 4871 Process Control (PCC)

H Certifications	
-No Symbol	No Certification Required
-PARR	Parr Certification
-ASME	ASME Certification
-PED	PED Certification



The system above has three 250 mL tubular reactors operating in parallel and controlled by a 4871 Process Controller with operator interface on a single PC. This system has weighed and/or heated feed tanks and a two-stage pressure let down.